

Hermetically Sealed SMA Female to SMA Female Adapter, Bulkhead

Applications

- Vacuum
- High pressure
- Airtight seal



Electrical

Impedance	50 ohm
Frequency Range	DC-18 GHz
VSWR	≤1.25
Operating Voltage (AC)	≤250 Vrms
Dielectric Withstanding Voltage (AC)	≤1500 Vrms
Insulation Resistance	≥5000 MOhms
Hermetically (Leak Rate)	<1 x 10 ⁻⁸ cc/sec of helium at 1 atm
Operating Temperature	-25°C to +125°C
IP Rate	IP68 when mated

Mechanical

Connector Body	Passivated stainless steel, Gold Plated
Center Contact	Beryllium Copper, Gold Plated
Inner Seal Body and Finish	Kovar, Gold Plated
Inner Seal Insulator	Glass
Coupling Torque Recommended	0.9 Nm

Drawing (Dimensions are in mm)

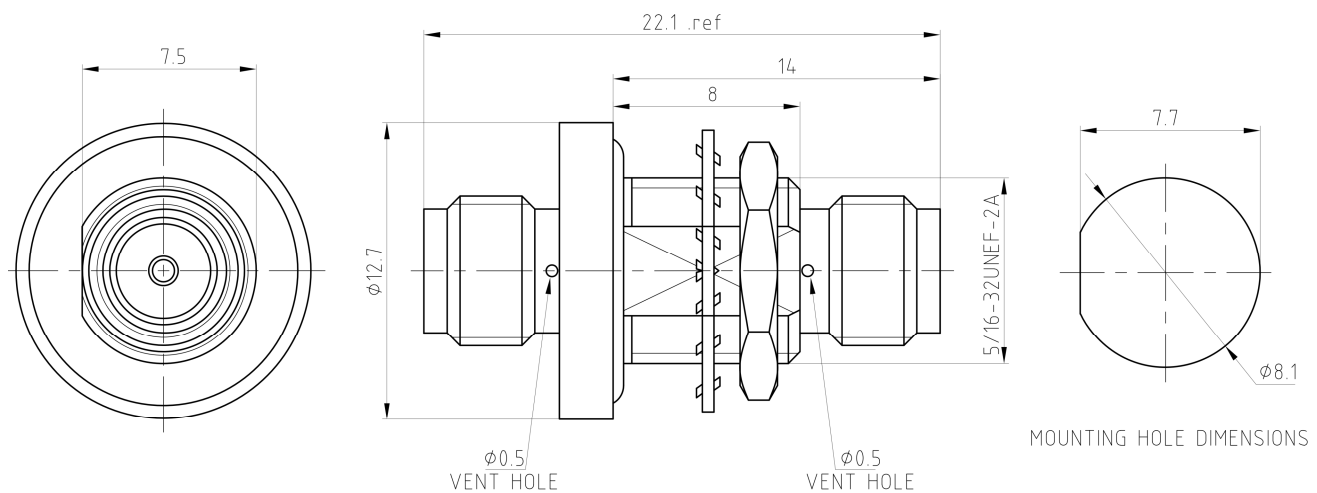

Hermetically Sealed SMA Female to SMA Female Adapter, Bulkhead

Typical Test Data

