

**WR34 to 2.92mm Female Waveguide to Coaxial Adapter
UG1530/U Flange, End Launch**

Rev 5

Electrical

Frequency Range	21.7-33 GHz
VSWR	1.2 max

Configuration

Waveguide Size	IEC	260
	EIA	WR34
Flange	UG1530/U	
Coax Connector	2.92mm Female	
Body Geometry	End-launch	

Mechanical & Environmental

Waveguide Body	Cu, acid pickling and passivation, anti-corrosive paint
Connector Body	Passivated stainless steel
Center Contact	Gold plated beryllium copper
Operating Temperature	-40°C to +85°C
Connector Interface	MIL-STD-348
RoHS	Compliant under exemptions 6 (b) or 6 (c)
Net Weight	Approx 35g

Note

* Paint in grey or black by default, other colors available.



**WR34 to 2.92mm Female Waveguide to Coaxial Adapter
UG1530/U Flange, End Launch**

Rev 5

Dimensions(mm)

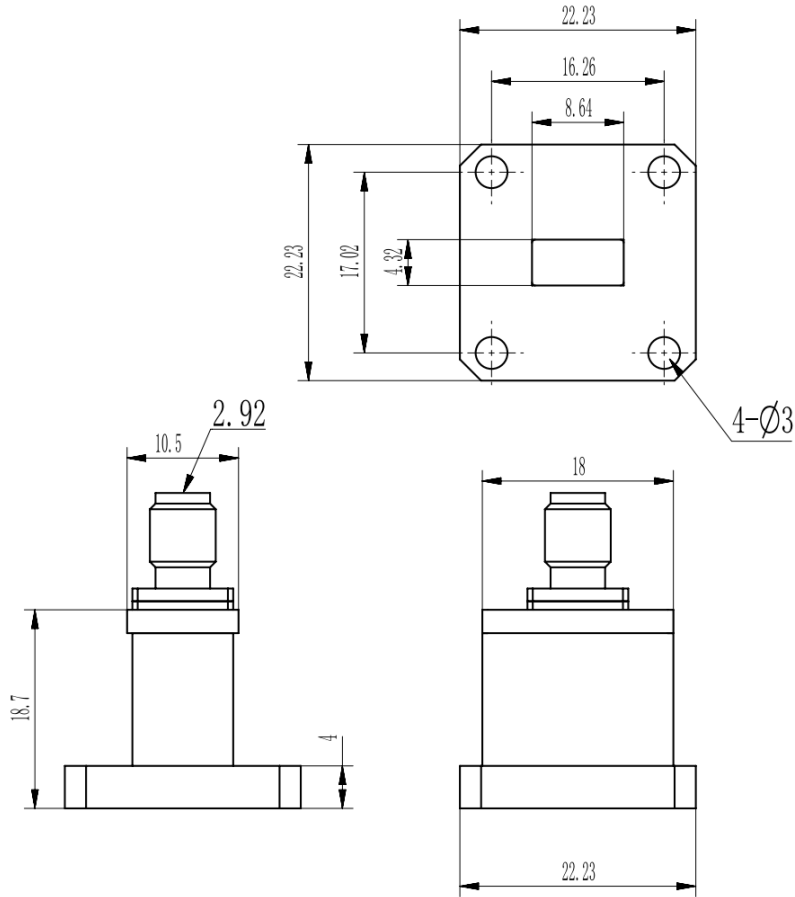

Flange Comparison (mm)

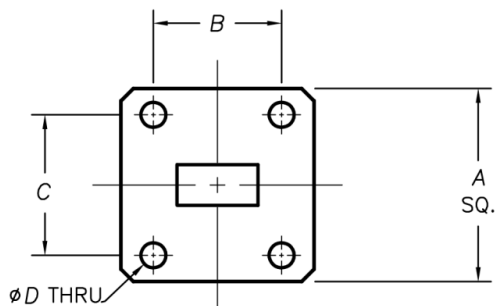

* The purpose of this comparison is to provide a quick reference of different flange standards. Great care has been given, nevertheless there might be a few mistakes.

* Please check the flange compatibility before ordering. Customized flanges are available.

WG SIZE	CONFORMING STANDARD	A	B	C	D
WR34	RF ONE:AWR34292EA	22.23	16.26	17.02	3.00
	USA:MIL3922/63-009(UG1530/U)	22.23	16.26	17.02	2.95



**WR34 to 2.92mm Female Waveguide to Coaxial Adapter
UG1530/U Flange, End Launch**

Rev 5

Typical Test Data at 25°C

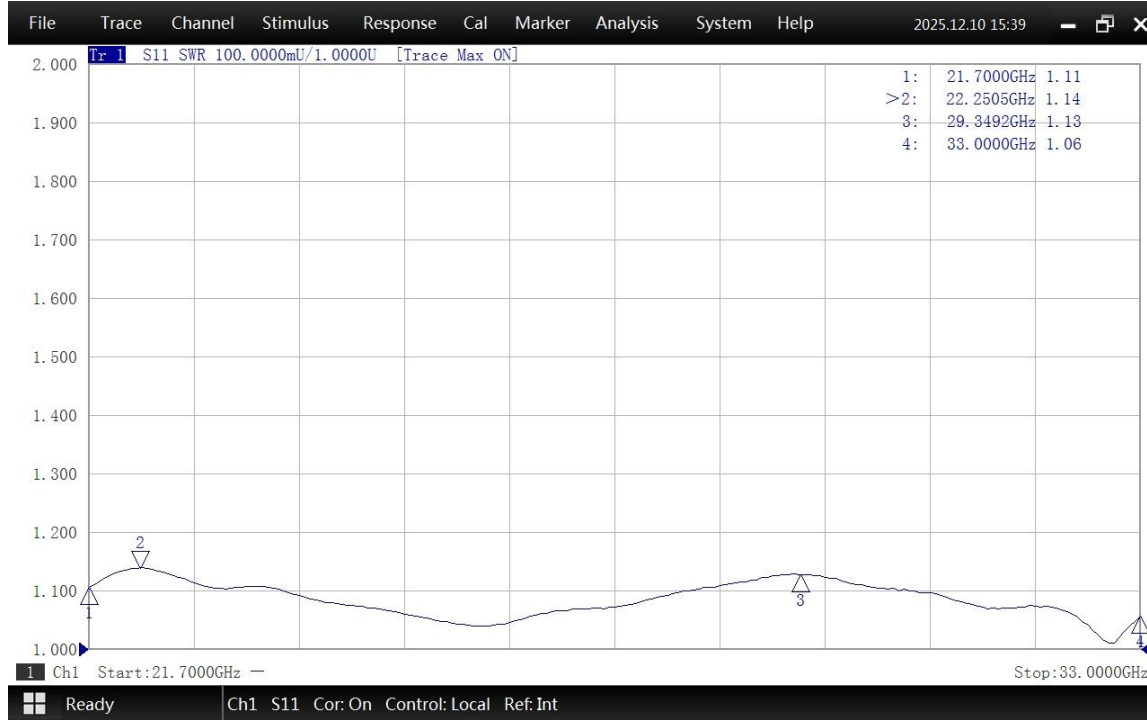

VSWR

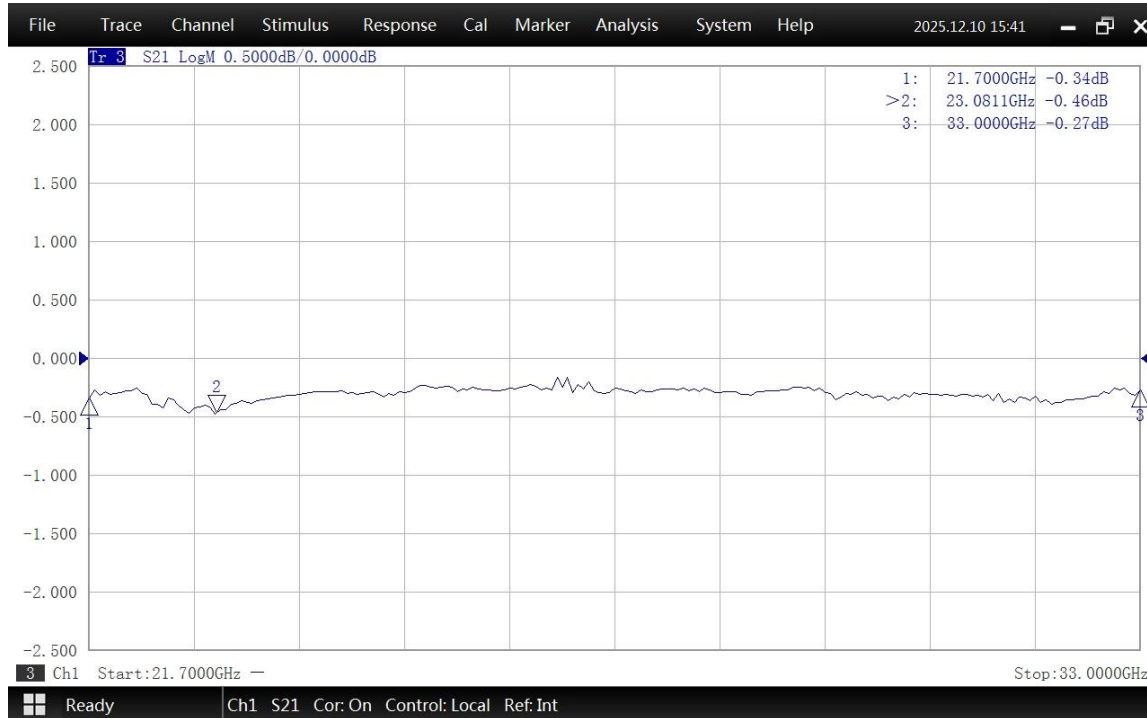

Insertion Loss*

* In Insertion Loss (IL) testing, adapters are measured back-to-back. To obtain the loss of a single adapter, divide the measured value by two.