

WRD750 to TNC Female Waveguide to Coaxial Adapter Square Cover Flange, Right Angle

Electrical

Frequency Range	7.5-18 GHz
VSWR	1.3 max
Average Power	150 Watts

Configuration

Waveguide Size	WRD750
Flange	Square Cover, FPWRD750
Coax Connector	TNC Female
Body Geometry	Right Angle

Mechanical & Environmental

Waveguide Body	Aluminum, conductive oxidation, anti-corrosive paint
Connector Body	Passivated stainless steel
Center Contact	Gold plated beryllium copper
Operating Temperature	-40°C to +85°C
Connector Interface	MIL-STD-348
RoHS	Compliant under exemptions 6 (b) or 6 (c)
Net Weight	Approx 100g

Note

* Paint in grey or black by default, other colors available.

**WRD750 to TNC Female Waveguide to Coaxial Adapter
Square Cover Flange, Right Angle**

Dimensions(mm)

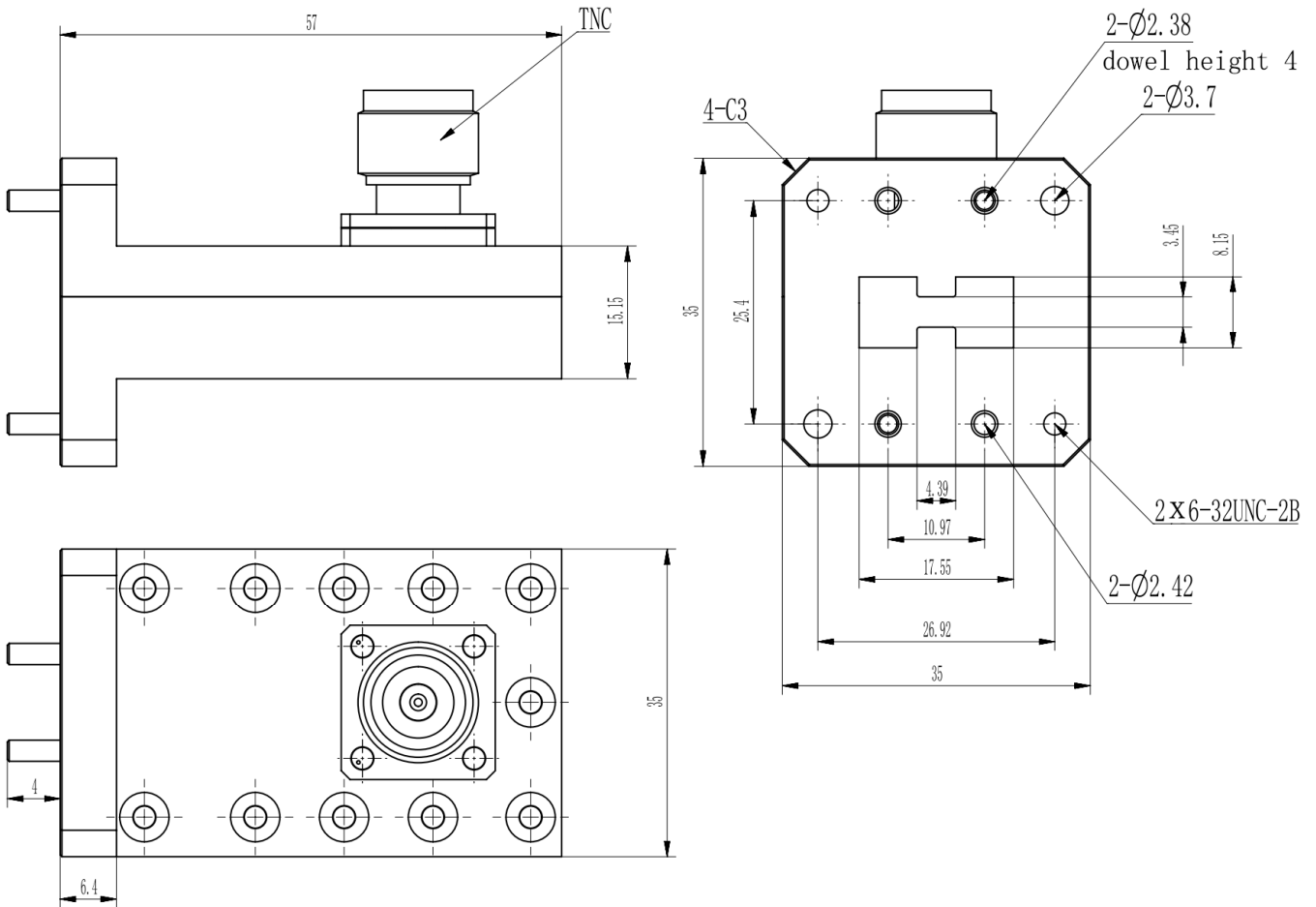

**WRD750 to TNC Female Waveguide to Coaxial Adapter
Square Cover Flange, Right Angle**

Typical Test Data at 25°C

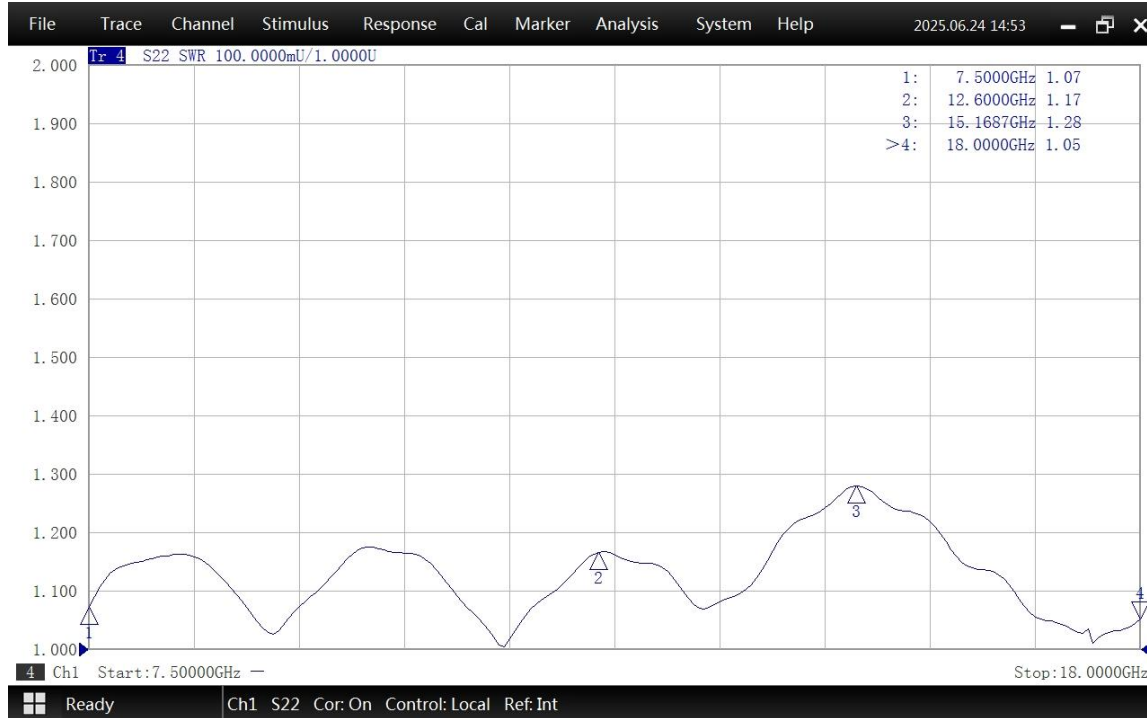

VSWR

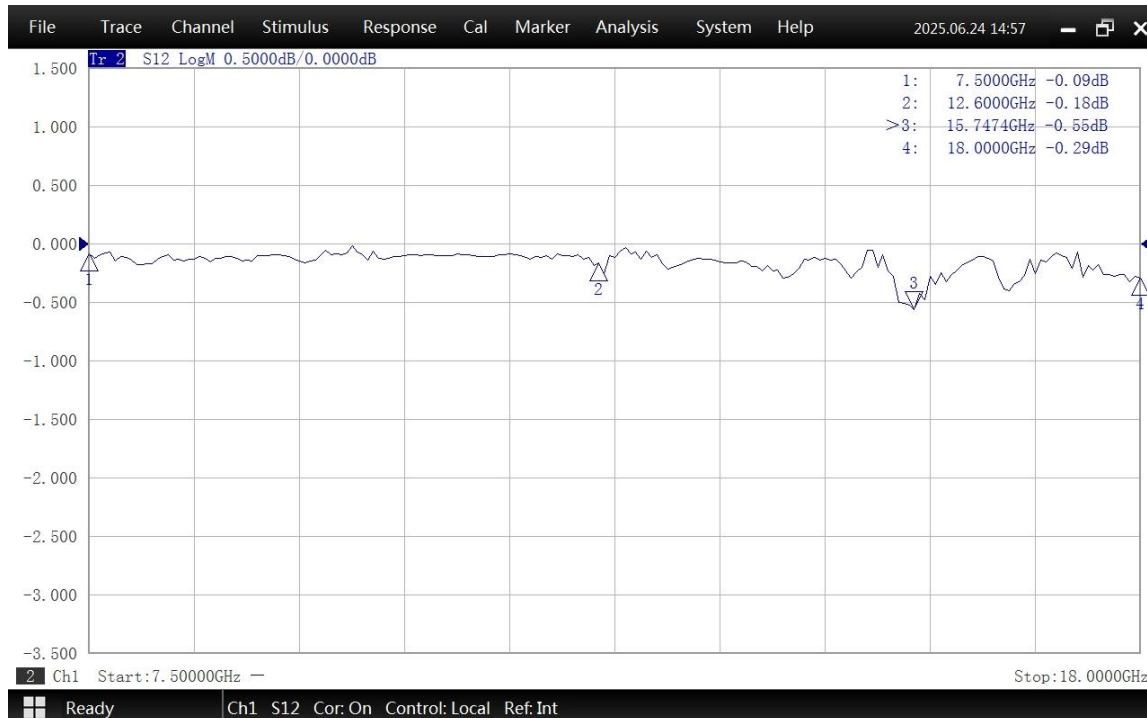

Insertion Loss*

* In Insertion Loss (IL) testing, adapters are measured back-to-back. To obtain the loss of a single adapter, divide the measured value by two.