

Power Divider

PDM-0069027-S4

4 Way, 0.69-2.7 GHz, SMA, 30 Watts



Rev 1

Electrical & Environmental

Impedance	50 ohm
Number of Output Ports	4 Way
Frequency Range	0.69-2.7 GHz
Insertion Loss	≤ 0.8dB (Excluding theoretical loss 6.0dB)
Input VSWR	1.25 max
Output VSWR	1.2 max
Isolation	18dB min
Amplitude Balance	≤ ±0.3dB
Phase Balance	≤ ±3°
Average Power Rating	30 Watts (As Divider), 2 Watts (As Combiner)
Operating Temperature	-35°C ~ +75°C

Mechanical

Input/Output Connectors	SMA Female
Housing Finishing	Sandblasting Aluminum with conductive oxidation
Outline Dimensions	52*64*12 (mm)
Weight	About 95g

Dimensions(Unit: mm/[inch], Tolerance: ±0.3mm)

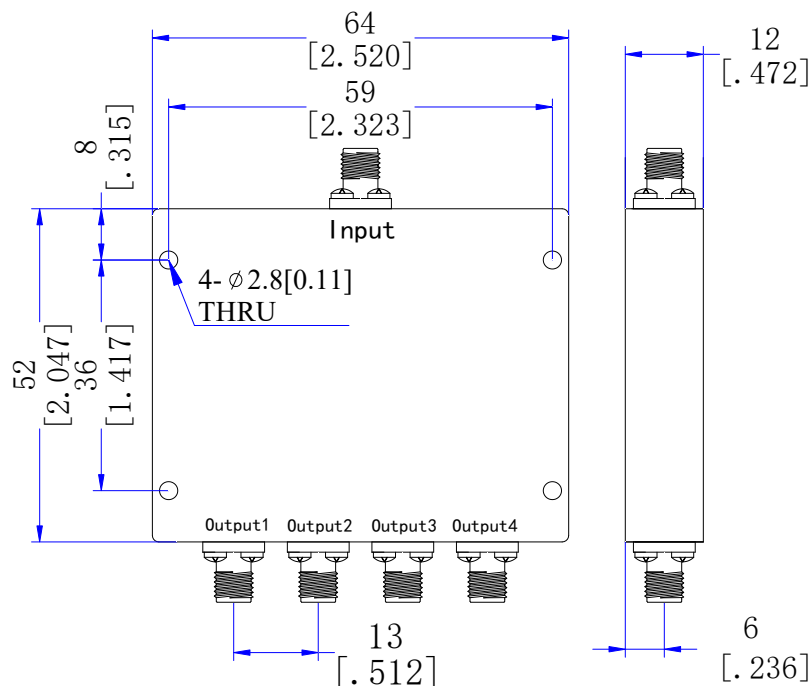



Typical Test Data

