

25 dBi Gain, 49.8-75.8 GHz, WR15 Standard Gain Horn with UG385/U

Flange

Rev 1

Electrical

Frequency Range	49.8-75.8 GHz
Norminal Gain	25 dBi
Polarization	Linear
VSWR	1.2 max
3dB Beamwidth	E-Plane: 7.6~10.7 deg, H-Plane: 7.3~10.9 deg
Operating Temperature	-40°C ~ +70°C

Mechanical

Waveguide Size	WR15
Flange Type	UG385/U Round Cover Flange
Body Material and Finish	Copper, painting over gold plating

Dimensions(mm)

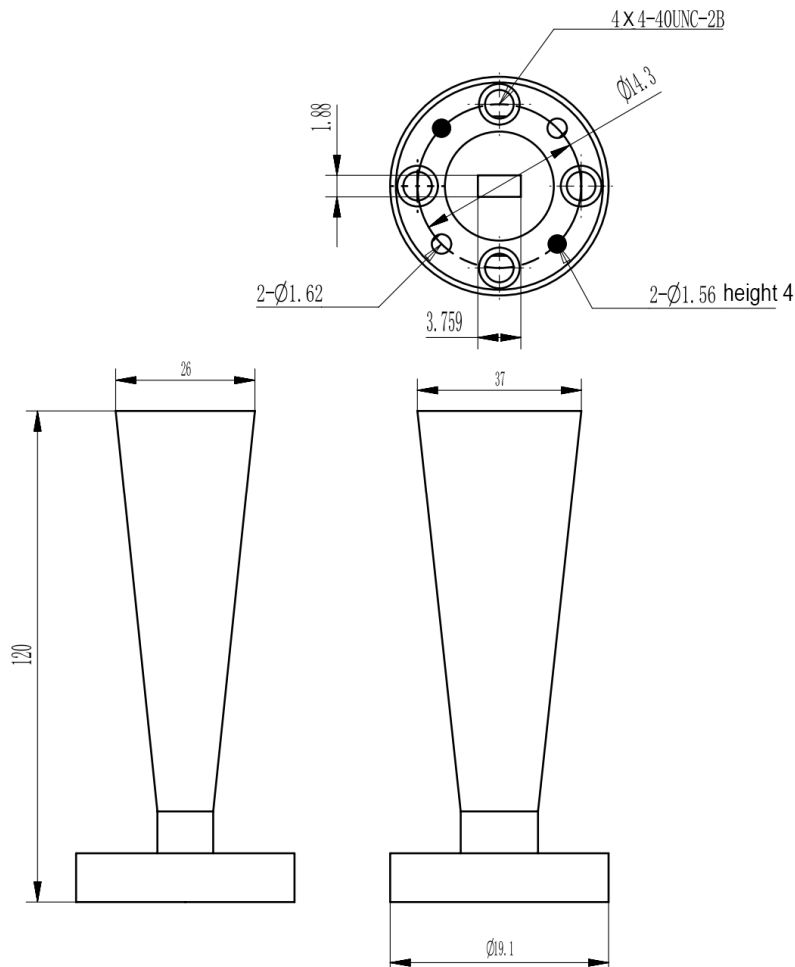

Simulated Antenna Patterns

