



## 10 dBi Gain, 2.6-3.95 GHz, WR284 Standard Gain Horn with N Female Port

Rev 1

### Electrical

Frequency Range	2.6-3.95 GHz
Norminal Gain	10 dBi
Polarization	Linear
VSWR	1.4 max
3dB Beamwidth	E-Plane: 35.0~55.5 deg, H-Plane: 34.6~56.6 deg
Operating Temperature	-40°C~+70°C

### Mechanical

Waveguide Size	WR284
Flange Type	UDR32 Rectangular Cover Flange
Body Material and Finish	Aluminum, Painted
RF Connector	N Female
Net Weight	Approx 1kg

### Dimensions(mm)

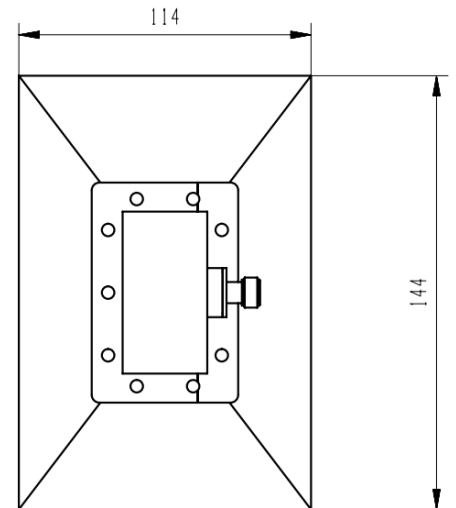
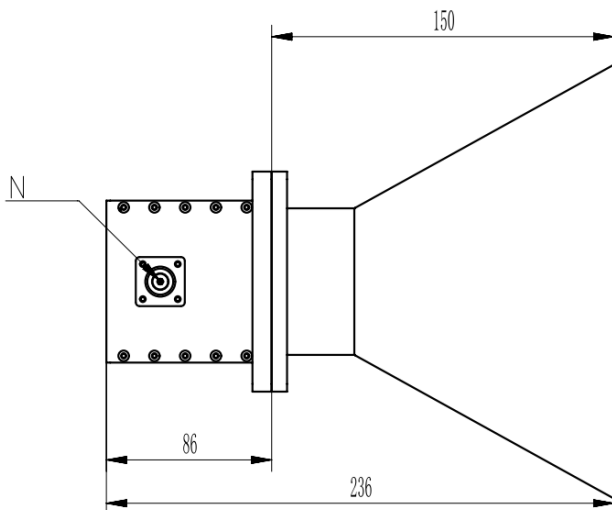



10 dBi Gain, 2.6-3.95 GHz, WR284 Standard Gain Horn with N Female Port

Rev 1

Typical VSWR

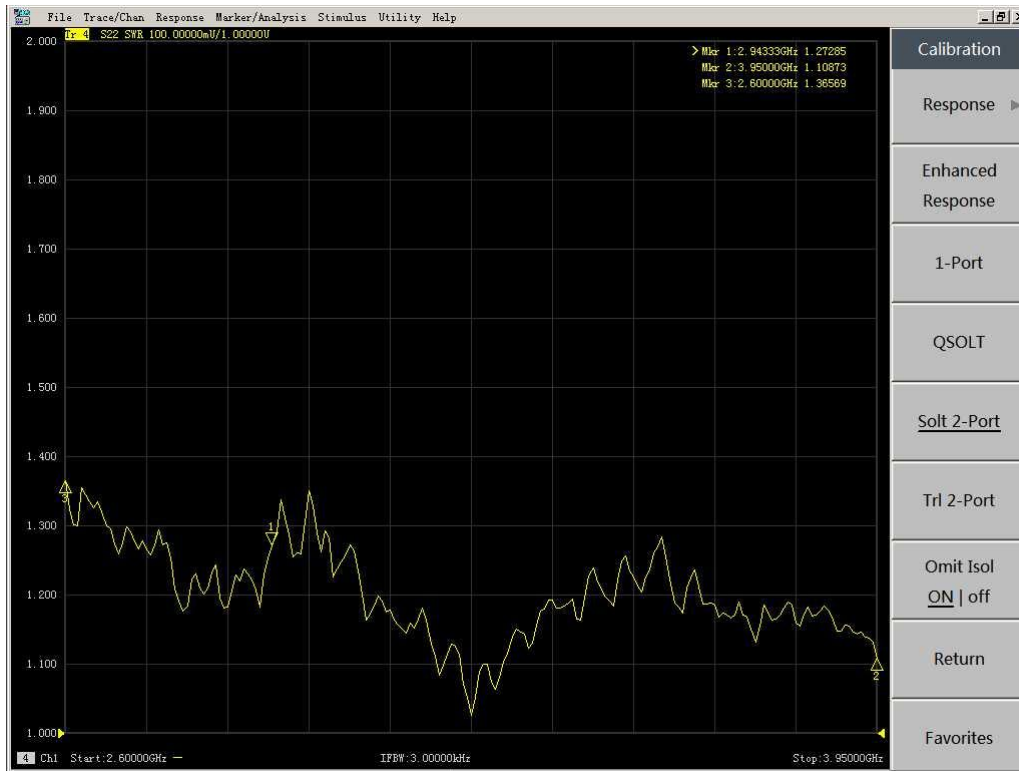

# Simulated Antenna Patterns

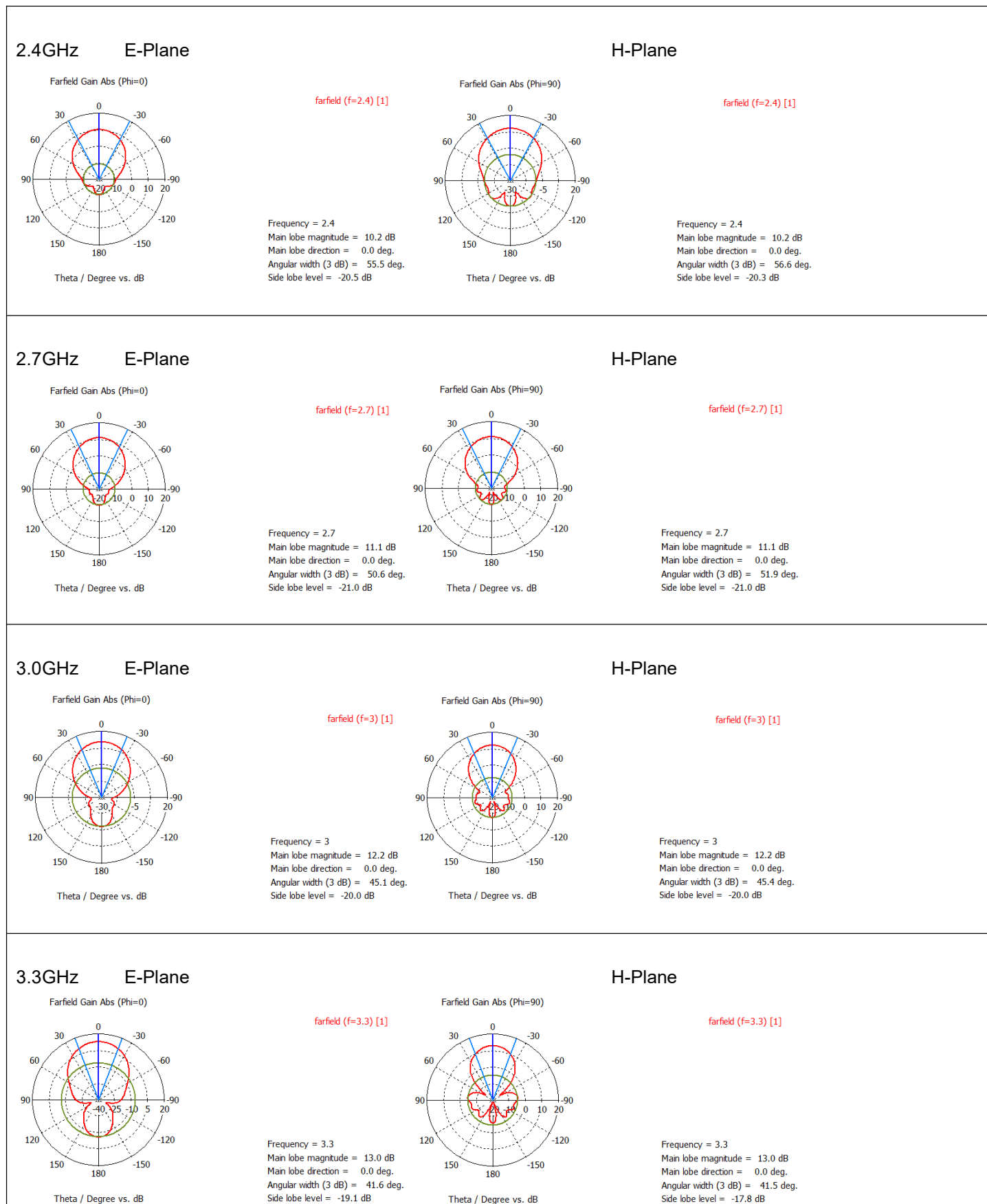

### 3.7GHz E-Plane

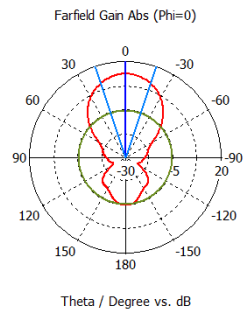

farfield (f=3.7) [1]

Frequency = 3.7  
 Main lobe magnitude = 13.8 dB  
 Main lobe direction = 0.0 deg.  
 Angular width (3 dB) = 37.8 deg.  
 Side lobe level = -19.0 dB

### H-Plane

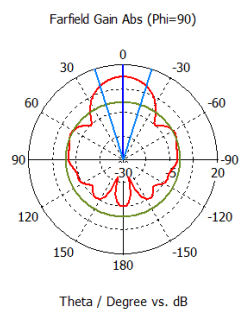

farfield (f=3.7) [1]

Frequency = 3.7  
 Main lobe magnitude = 13.8 dB  
 Main lobe direction = 0.0 deg.  
 Angular width (3 dB) = 34.7 deg.  
 Side lobe level = -13.0 dB

### 3.95GHz E-Plane

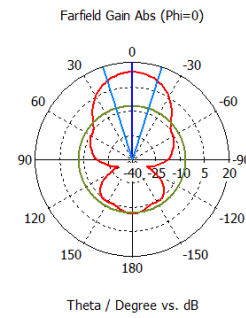

farfield (f=3.95) [1]

Frequency = 3.95  
 Main lobe magnitude = 14.2 dB  
 Main lobe direction = 0.0 deg.  
 Angular width (3 dB) = 35.0 deg.  
 Side lobe level = -20.6 dB

### H-Plane

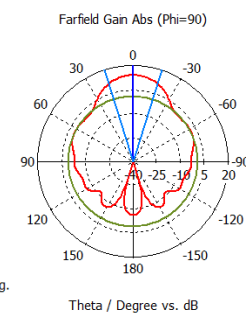

farfield (f=3.95) [1]

Frequency = 3.95  
 Main lobe magnitude = 14.2 dB  
 Main lobe direction = 0.0 deg.  
 Angular width (3 dB) = 34.6 deg.  
 Side lobe level = -13.1 dB

## Gain

