

10 dBi Gain, 9.84-15 GHz, WR75 Standard Gain Horn with UBR120 Flange

Rev 2

Electrical

Frequency Range	9.84-15 GHz
Norminal Gain	10 dBi
Polarization	Linear
VSWR	1.25 max
3dB Beamwidth	E-Plane: 34.6~51.7 deg, H-Plane: 36.0~57.7 deg
Operating Temperature	-40°C~+70°C

Mechanical

Waveguide Size	WR75
Flange Type	UBR120 Square Cover Flange
Body Material and Finish	Aluminum, Painted

Dimensions(mm)

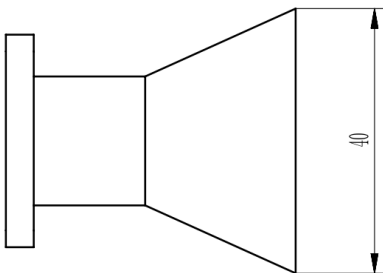
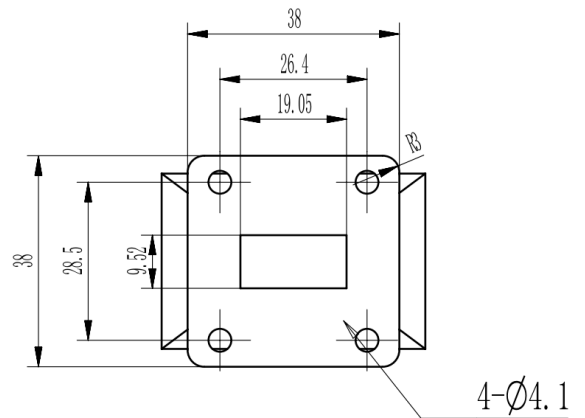
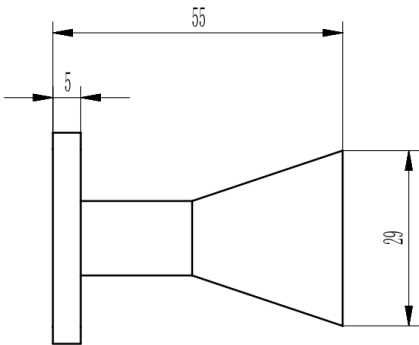

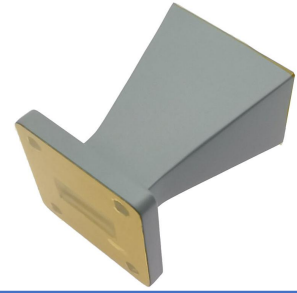

10 dBi Gain, 9.84-15 GHz, WR75 Standard Gain Horn with UBR120 Flange

Rev 2

Typical Test Data

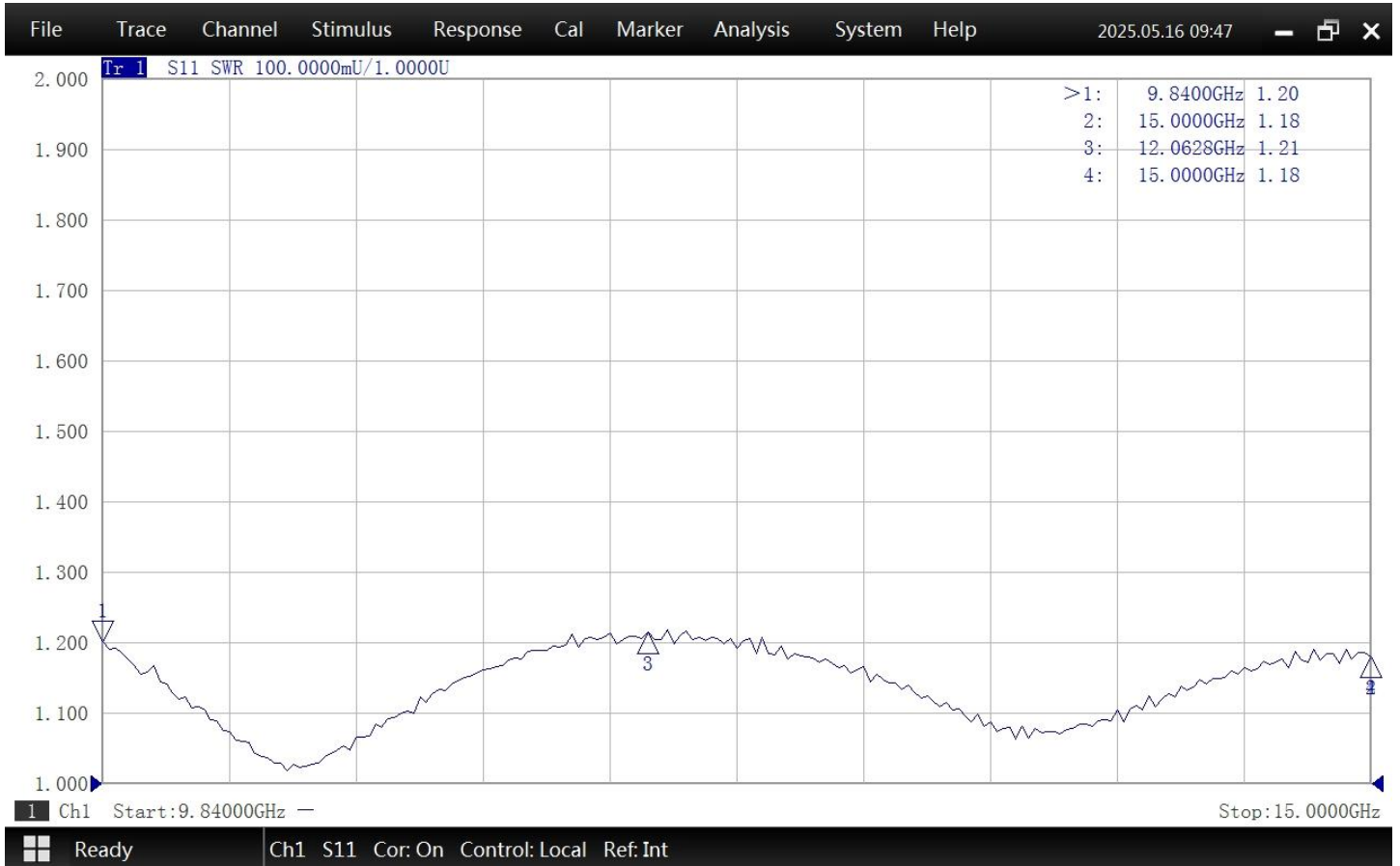

Simulated Antenna Patterns

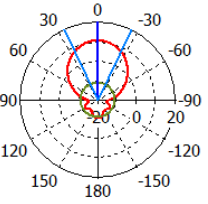
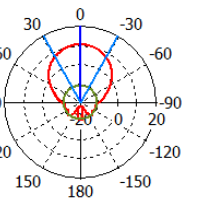
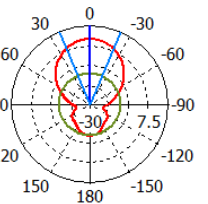
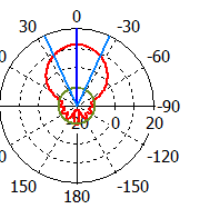
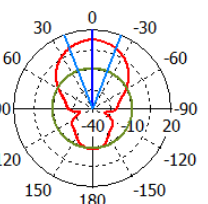
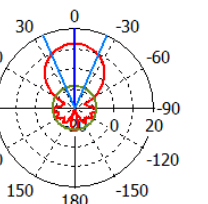
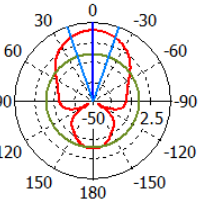
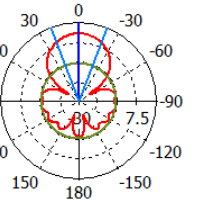
<p>9.85GHz E-Plane</p> <p>Farfield Gain Abs (Phi=0)</p>  <p>Theta / Degree vs. dB</p>	<p>farfield (f=9.85) [1]</p> <p>Frequency = 9.85 Main lobe magnitude = 10.6 dB Main lobe direction = 0.0 deg. Angular width (3 dB) = 51.7 deg. Side lobe level = -21.2 dB</p>	<p>9.85GHz H-Plane</p> <p>Farfield Gain Abs (Phi=90)</p>  <p>Theta / Degree vs. dB</p>	<p>farfield (f=9.85) [1]</p> <p>Frequency = 9.85 Main lobe magnitude = 10.6 dB Main lobe direction = 0.0 deg. Angular width (3 dB) = 57.7 deg. Side lobe level = -21.2 dB</p>
<p>11GHz E-Plane</p> <p>Farfield Gain Abs (Phi=0)</p>  <p>Theta / Degree vs. dB</p>	<p>farfield (f=11) [1]</p> <p>Frequency = 11 Main lobe magnitude = 11.7 dB Main lobe direction = 0.0 deg. Angular width (3 dB) = 45.8 deg. Side lobe level = -21.8 dB</p>	<p>11GHz H-Plane</p> <p>Farfield Gain Abs (Phi=90)</p>  <p>Theta / Degree vs. dB</p>	<p>farfield (f=11) [1]</p> <p>Frequency = 11 Main lobe magnitude = 11.7 dB Main lobe direction = 0.0 deg. Angular width (3 dB) = 50.1 deg. Side lobe level = -21.8 dB</p>
<p>12GHz E-Plane</p> <p>Farfield Gain Abs (Phi=0)</p>  <p>Theta / Degree vs. dB</p>	<p>farfield (f=12) [1]</p> <p>Frequency = 12 Main lobe magnitude = 12.5 dB Main lobe direction = 0.0 deg. Angular width (3 dB) = 42.3 deg. Side lobe level = -21.1 dB</p>	<p>12GHz H-Plane</p> <p>Farfield Gain Abs (Phi=90)</p>  <p>Theta / Degree vs. dB</p>	<p>farfield (f=12) [1]</p> <p>Frequency = 12 Main lobe magnitude = 12.5 dB Main lobe direction = 0.0 deg. Angular width (3 dB) = 47.2 deg. Side lobe level = -21.1 dB</p>
<p>13GHz E-Plane</p> <p>Farfield Gain Abs (Phi=0)</p>  <p>Theta / Degree vs. dB</p>	<p>farfield (f=13) [1]</p> <p>Frequency = 13 Main lobe magnitude = 13.3 dB Main lobe direction = 0.0 deg. Angular width (3 dB) = 38.9 deg. Side lobe level = -20.6 dB</p>	<p>13GHz H-Plane</p> <p>Farfield Gain Abs (Phi=90)</p>  <p>Theta / Degree vs. dB</p>	<p>farfield (f=13) [1]</p> <p>Frequency = 13 Main lobe magnitude = 13.3 dB Main lobe direction = 0.0 deg. Angular width (3 dB) = 41.5 deg. Side lobe level = -19.0 dB</p>

14GHz E-Plane

Farfield Gain Abs (Phi=0)

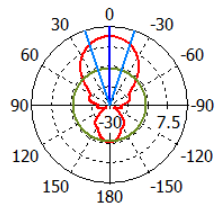

Theta / Degree vs. dB

farfield (f=14) [1]

Frequency = 14
 Main lobe magnitude = 14.0 dB
 Main lobe direction = 0.0 deg.
 Angular width (3 dB) = 36.2 deg.
 Side lobe level = -20.1 dB

H-Plane

Farfield Gain Abs (Phi=90)

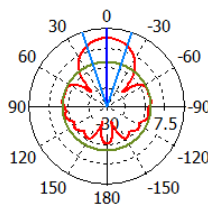

Theta / Degree vs. dB

farfield (f=14) [1]

Frequency = 14
 Main lobe magnitude = 14.0 dB
 Main lobe direction = 0.0 deg.
 Angular width (3 dB) = 37.1 deg.
 Side lobe level = -15.3 dB

15GHz E-Plane

Farfield Gain Abs (Phi=0)

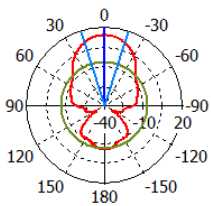

Theta / Degree vs. dB

farfield (f=15) [1]

Frequency = 15
 Main lobe magnitude = 14.0 dB
 Main lobe direction = 0.0 deg.
 Angular width (3 dB) = 34.6 deg.
 Side lobe level = -20.0 dB

H-Plane

Farfield Gain Abs (Phi=90)

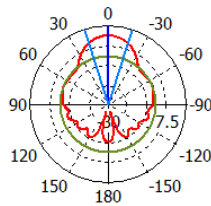

Theta / Degree vs. dB

farfield (f=15) [1]

Frequency = 15
 Main lobe magnitude = 14.0 dB
 Main lobe direction = 0.0 deg.
 Angular width (3 dB) = 36.0 deg.
 Side lobe level = -13.3 dB